

DATASHEET

HALFCOUPLER 500KG / 50MM

Art.Nr. 151 50 500 11 T

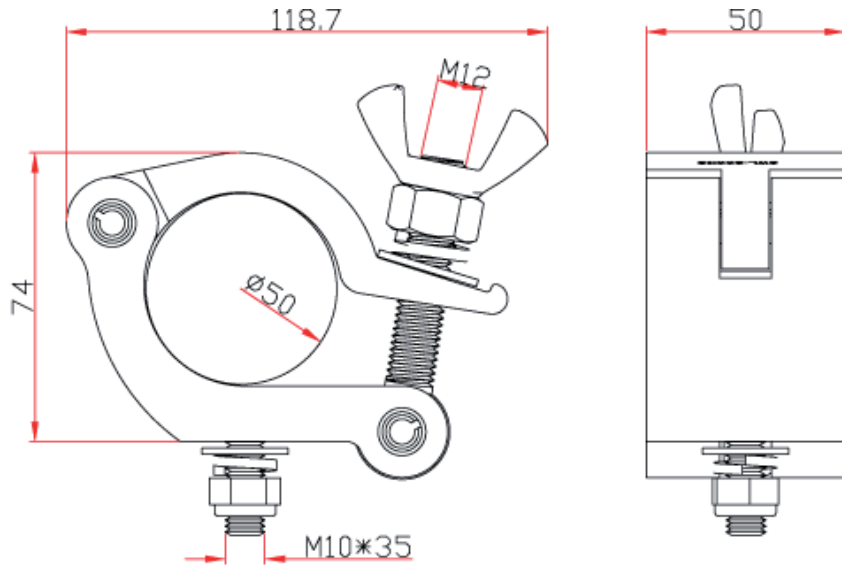

Rohrdurchmesser <i>Tube</i>	48-51 mm
Belastbarkeit (WLL) <i>Tensile load</i>	500 kg
Farbe <i>Colour</i>	silber <i>silver</i>
Bauform <i>Variaty</i>	Halbschelle <i>Halfcoupler</i>
Verschluss <i>Screw plug</i>	M12 Flügelmutter, Unterlegscheibe <i>M12 wing nut, washer</i>
Abgang <i>Retaining screw</i>	M10 Senkkopfschraube, Stopmutter <i>M10 bolt, lock nut</i>
Breite <i>Width</i>	50 mm
Zugbelastung <i>Tensile load</i>	750 kg
Material <i>Material</i>	Aluminium 6061 T6
Gewicht <i>Weight</i>	0,41 kg
Verpackungseinheit <i>Unit</i>	25 Stück <i>25 pieces</i>